

PRODUCT DATA SHEET

MW154FRE



FIRE RATED WHITE METAL CEILING AIR EXTRACT VALVE



BEFORE A FIRE



SEALED AFTER A FIRE

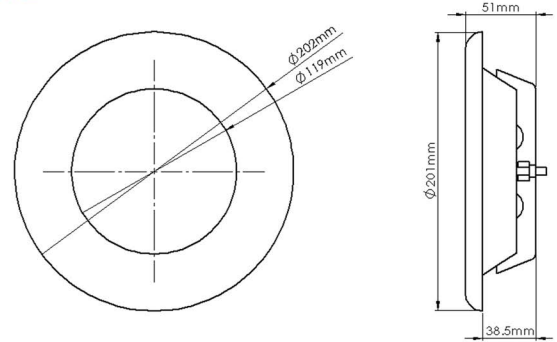

MANUFACTURER:	VERPLAS LTD
PART NUMBER:	MW154FRE
SIZE:	150mm \varnothing
FOR USE WITH:	VERPLAS SYSTEM 150
BOX QUANTITY:	7
INDIVIDUAL WEIGHT:	510g
COLOUR	White
FIRE RATING	60 Minutes

SPECIFICATION DETAILS

The MW154FRE 150mm diameter Round Fire Rated Extract Valve is manufactured from White Epoxy Powder Coated Steel. The valve has a male spigot to fit inside the System 150 duct.

The MW154FRE Extract Air Valve is fully adjustable and has a locking nut to fix the position of the control disc upon commissioning. It is supplied complete with a fixing body with pre-drilled holes for installation.

The MW154FRE incorporates an integral intumescent material and has been fire tested to BS EN 1365-2:2014 with 60 minute rating for ceilings.

MW154FRE has been designed for use with Verplas System 150 Round.

AIRFLOW	RESISTANCE
8 l/s	1.70 pa
13 l/s	2.60 pa
21 l/s	6.00 pa
30 l/s	12.50 pa
60 l/s	49.60 pa
120 l/s	195.20 pa

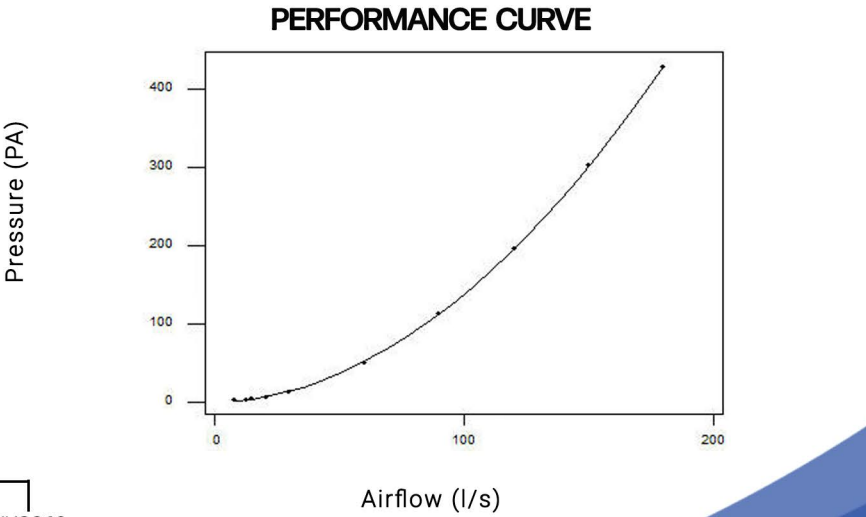

Associated Ancillaries

